

1. CAUTIONARY NOTES FOR SAFE USE OF THE PRODUCT

For the correct use of this product, read through this manual before use. The following safety symbol is indicated on the product to ensure safe use.



If this symbol is indicated on the product, the operator should refer to the explanation given in the instruction manual in order to avoid personnel injury or death to either themselves or other personnel, and/or damage to the instrument. The manual describes the special care the operator should exercise to avoid shock or other dangers that may result in injury or loss of life.

The following symbol marks are used only in this manual.



IMPORTANT

Indicates that operating the hardware or software in a particular manner may damage it or result in a system failure.



NOTE

Draws attention to information that is essential for understanding the operations and/or features of the product.

2. CHECKING PRODUCT SPECIFICATIONS AND THE CONTENTS OF PACKING

(1) Model Number and Specification Check

Check that the model number and specifications shown on the nameplate attached on the side of the product are as ordered.

(2) Contents of the Packing

Check that the packing contains the following items:

- VJS7 main unit, 1
- Instruction Manual (IM 77J01S07-01E), 1

Accessories:

- Tag number label, 1

3. GENERAL

This plug-in type transmitter is used in combination with transmitters which send displacement information of regulator valves by resistance change signals from a potentiometer, and converts the resistance change into isolated DC current or DC voltage signals.

- Output-2 can be selected from DC voltage signal, DC current signal, communication output (RS-485), or alarm output (2 relay contacts).

4. MOUNTING METHODS

4.1 Wall Mounting

Loosen the main unit-fixing screw of the transmitter to disconnect the main unit from the socket. Next, anchor the socket onto the wall with screws. Then, plug the main unit into the socket and secure the main unit with the main unit-fixing screw.

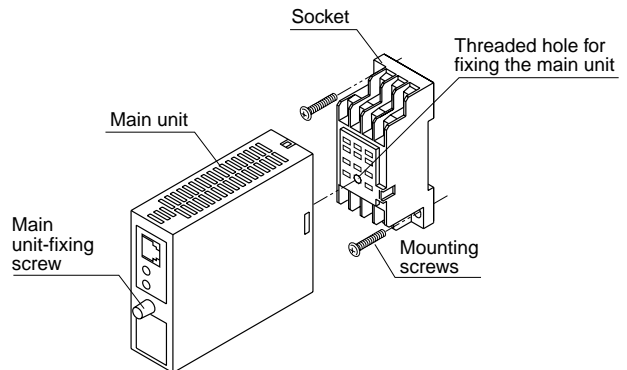

Fig. 4.1

4.1.1 Mounting Dimensions

Unit: mm

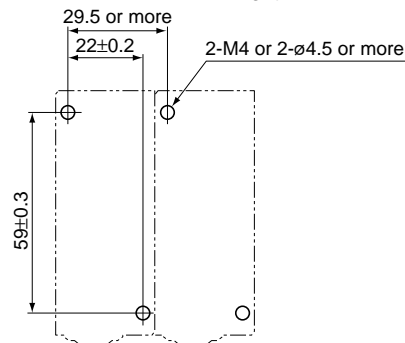

Fig. 4.2

4.2 DIN Rail Mounting

Locate the transmitter so that the DIN rail fits into the upper part of the DIN-rail groove at the rear of the socket, and fasten the socket using the slide lock at the lower part of the socket.

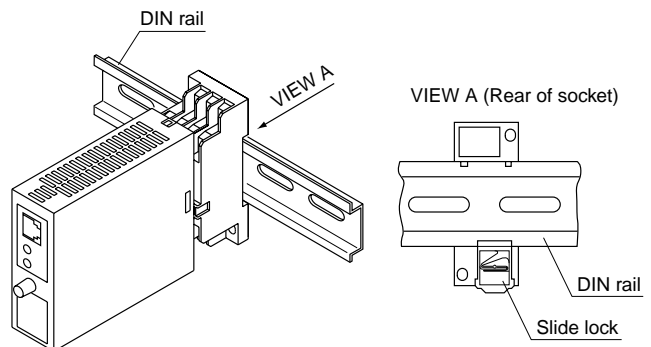

Fig. 4.3

Keep this manual in a safe place.

4.3 Mounting Using a Multi-mounting Base

For mounting using a multi-mounting base, see the Instruction Manual for VJCE (VJ Mounting Base).

4.4 Using Ducts

Wiring ducts should be installed at least 30 mm away from the top or bottom of the main unit.

4.5 In case of top-and-bottom close mounting

Transmitter should be mounted horizontally with its top and bottom slits being vertical. The top and bottom slits should not be covered.

The area for wiring is required above and below the transmitter (the area with slant lines).

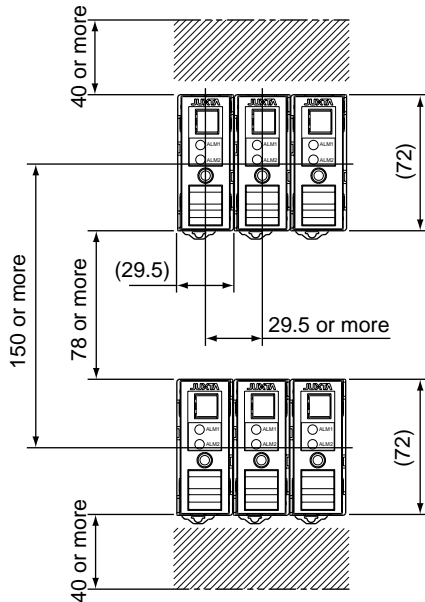

Fig. 4.3

5. INSTALLATION LOCATION

- For installation, avoid any location where the product may be subject to vibrations, corrosive gases, or large amounts of dust, or where the product is exposed to water, oil, solvents, direct sunlight, radioactive rays, or strong electric or magnetic fields.
- If there is a possibility that lightning could induce a high surge voltage on the power and signal lines, provide lightning arresters on the line between the field instrument and indoor instrument in order to protect the product. Install a dedicated arrester on the field side and another on the indoor side.

6. EXTERNAL WIRING



WARNING

Turn OFF the power supply and make sure that none of the cables are not in the hot-line state before carrying out the wiring to avoid the possibility of electric shock.

Wires are connected to the terminals of the isolator's socket. M3 screw terminals are provided for the connection of external signals. Attach a crimp-on lug to each wire for connection to the terminals.

- Recommended cables: A nominal cross-sectional area of 0.5 mm² or thicker for signal cables, and that of 1.25 mm² or thicker for power cables, and shielded twisted-pair cables (AWG24) for communication wiring cables.

- For mounting, use M3 screws and crimp-on terminals with insulating sleeves appropriate for the wires used. Tool of the crimp-on terminals to be used should be appropriate for the crimp-on terminals.
- Mount a breaker on the external place. Mount a switch or 5A circuit breaker on the place near by the instrument, within operator's reach. And attach the indication that it is for disconnecting the instrument.

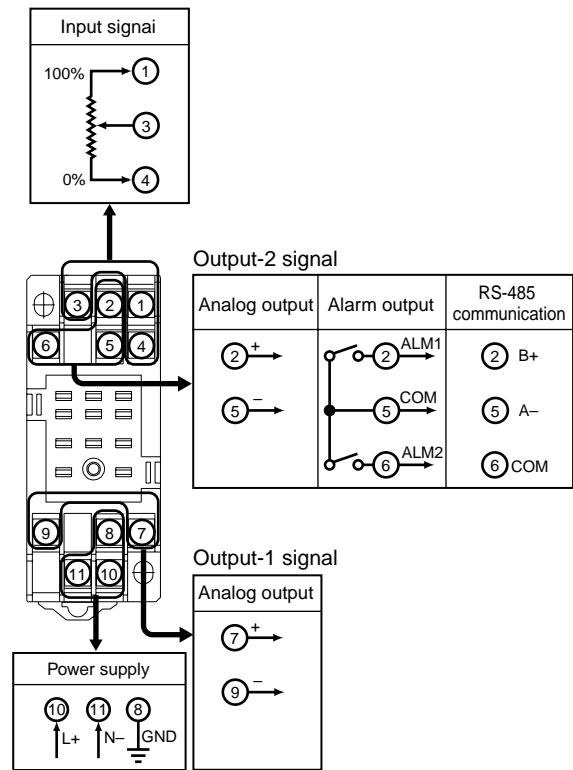

Fig. 6.1



NOTE

- Keep all sources of noise away from the power and signal cables. Otherwise, accuracy cannot be assured.
- Provide grounding to a grounding resistance of 100 Ω. The length of the grounding cable should be 20 m or less. Directly connect the lead from the ground terminal (terminal no. 8) of the isolator to the ground. Do not carry out daisy-chained inter-ground terminal wiring.
- Direct Current
- “Overvoltage category (Installation category)” describes a number which defines a transient overvoltage condition. It implies the regulation for impulse withstand voltage. “II” applies to electrical equipment which is supplied from the fixed installation like distribution board.
- “Pollution degree” describes the degree to which a solid, liquid, or gas which deteriorates dielectric strength or surface resistivity is adhering. “2” applies to normal indoor atmosphere. Normally, only non-conductive pollution occurs. Occasionally, however, temporary conductivity caused by condensation must be expected.
- Rated fuse of 125VDC, 1A is stored. However, operators can not replace the fuse.



IMPORTANT

- If this instrument is used in a manner not specified in this manual, the protection provided by this instrument may be impaired.
- If the product is operated by a power supply exceeding the specifications, the product may become extremely hot and, as a result, damaged. To prevent this, ensure the following before turning on the power.
 - (a) The voltage of the supplied power and the input signal level meet the specifications of the product.
 - (b) External wires are connected to the correct terminals (refer to Chapter 5).
- Do not operate the product in the presence of flammable or explosive gases or vapors. To do so is highly dangerous.
- The product is sensitive to static electricity; exercise care in operating it. Before you operate the product, touch a nearby metal part to discharge static electricity.

7. DESCRIPTION OF FRONT PANEL AND CONNECTION OF SETTING TOOLS

7.1 Front Panel

The communications connector in the front panel is used for setting up parameters through a PC (VJ77 PC-based Parameters Setting Tool) or the Handy Terminal. The alarm-1 and alarm-2 LEDs light up if an alarm occurs (those LEDs are provided only when the output-2 is specified for alarm output).

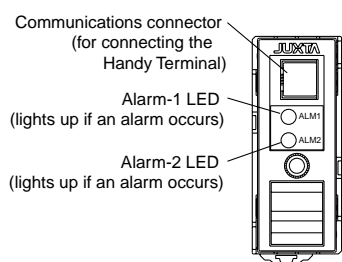

* The LEDs are provided only when output-2 is specified for alarm output.

Fig. 7.1 Front Panel

7.2 Connecting the Setting Tools

Connect the modular jack-to-connector adapter (E9786WH) to the JUXTA communication cable with 5-pin connector (F9182EE) and then connect this adapter to the communication connector of JUXTA.

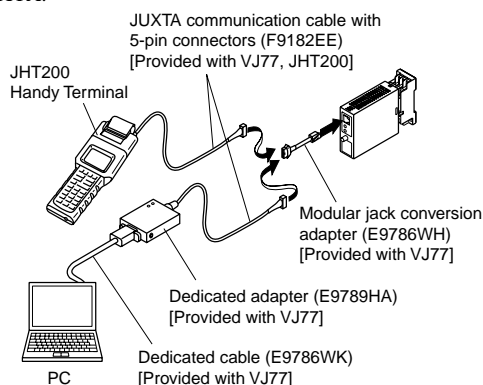

Fig. 7.2 Connecting the Setting Tools

8. SETTING PARAMETERS

Set the parameters using a PC (VJ77 PC-based Parameter Setting Tool) or the Handy Terminal. Refer to the list of parameters in this manual and the Instruction Manual for Handy Terminal (IM JF81-02E) or VJ77 PC-based Parameters Setting Tool (IM 77J01J77-01E).

8.1 Settings Related to Inputs and Outputs

8.1.1 Input range

Set the input range in P10: ZERO ADJ1 (setting of 0% of input) and in P11: SPAN ADJ1 (setting of 100% of input). Refer to "6. External Wiring" of this manual, and connect the signal cable from potentiometer to VJS7.

Input the value equivalent to 0% of input to VJS7, then, wait for 10 seconds. And select and set EXECUTE in P10: ZERO ADJ1. Also, input the value equivalent to 100% of input to VJS7, then, wait for 10 seconds. And set and select EXECUTE in P11: SPAN ADJ1. The input range is set after completing the above operations.

8.1.2 Setting of Burnout

Select and set OFF, UP, or DOWN in D30: BURN OUT.

8.1.3 Direction of Output Action

Analog output signals can be reversed. To reverse the signal from output-1, set D38: OUT1 DR to REVERSE. For output-2, set D39 OUT2 DR to REVERSE. To return the output-1 signal to normal, set D38: OUT1 DR to DIRECT. For output-2, set D39: OUT2 DR to DIRECT.

8.2 Settings Related to Communication Function

Set the following parameters when output-2 is specified for communication function. For more information on the communication function, see the Instruction Manual for VJ Series Communication Function (IM 77J1J11-01E).

8.2.1 Communication Protocol

Set the communication protocol by selecting from among PC-LINK, PC-LINK WITH SUM, MODBUS ASCII, MODBUS RTU, and LADDER in F01: PROTOCOL.

8.2.2 Communication Address

Set the address number of the isolator numerically in a range of 1 to 99 in F02: ADDRESS.

8.2.3 Baud Rate

Set the baud rate by selecting from among 1200, 2400, 4800, and 9600 bps in F03: BAUD RATE.

8.2.4 Parity

Select and set NONE, EVEN, or ODD in F04: PARITY.

8.2.5 Data Length

Select and set 7 bits or 8 bits in F05: DATA LEN.

8.2.6 Stop Bit

Select and set 1 bit or 2 bits in F06: STOP BIT.

8.3 Settings Related to Alarm Output

Set the following parameters when output-2 is specified for alarm output.

8.3.1 Alarm Setpoints

Set the alarm setpoints of alarm-1 and alarm-2 in E03: SET POINT1 and E04: SET POINT2 numerically.

- Setting range: A range of 0 to 100% of input range
- Setting resolution: 0.1%

8.3.2 Direction of Alarm Action

Select the direction of alarm-1 action and that of alarm-2 action from among HIGH ALM (high-limit alarm) and LOW ALM (low-limit alarm) and set each in E05: ALM1 ACTION (direction of alarm-1 action) or E06: ALM2 ACTION (direction of alarm-2 action).

- To activate alarm status when input signal \geq alarm setpoint, select HIGH ALM.
- To activate alarm status when input signal \leq alarm setpoint, select LOW ALM.

8.3.3 Hysteresis

Set alarm-1 and alarm-2 hysteresis, in E09: HYSTERESIS1 and E10: HYSTERESIS2. Hysteresis is a value added to the alarm setpoint in order for an alarm status to be released (to normal) after the alarm status has been activated. The alarm status will be released in the following conditions, depending on the direction of alarm action.

- * When HIGH ALM (high-limit alarm) is set: Alarm is released when input signal $<$ (alarm setpoint - hysteresis).
- * When LOW ALM (low-limit alarm) is set: Alarm is released when input signal $>$ (alarm setpoint + hysteresis).
- Setting range: A range of 0 to 100% of input range
- Setting resolution: 0.1%

8.3.4 Alarm ON Delay and Alarm OFF Delay

Set alarm-1 and alarm-2 ON delays in E11: ON DELAY1 and E12: ON DELAY2 and then alarm-1 and alarm-2 OFF delays in E13: OFF DELAY1 and E14: OFF DELAY2.

An alarm ON delay is a delay time from the establishment of alarm condition to alarm output; an alarm OFF delay is a delay time from the establishment of return-to-normal condition to output.

- Setting range: 0 to 999 seconds
- Setting resolution: 1 second (Note that about 0.2 second will be added to set time to prevent erroneous operation.)

For example, when an alarm ON delay is set to 1 second, alarm output is generated if alarm status continues for more than 1 second after the input value exceeds the alarm setpoint. Further, when an alarm OFF delay is set to 2 seconds, alarm output is released if normal condition continues for more than 2 seconds after the input value has returned to normal from the alarm status.

8.3.5 Direction of Relay Action

Set the direction of relay energizing in alarm-1 normal condition and alarm-2 normal condition by selecting from among NRM DE-ENERGIZED (de-energized under normal condition) and NRM ENERGIZED (energized under normal condition) in E15: RL1 ACTION and E16: RL2 ACTION and set them.

9. DESCRIPTION OF ALARM ACTIONS

This chapter describes examples of alarm actions under the following conditions.

Item	Alarm-1		Alarm-2	
	Parameter	Setpoint	Parameter	Setpoint
Direction of alarm action	E05:ALM1 ACTION	High-limit alarm	E06:ALM2 ACTION	Low-limit alarm
Alarm setting	E01:SET POINT1	80%	E02:SET POINT2	15%
Hysteresis	E07:HYSTERESIS1	10%	E08:HYSTERESIS2	5%
Alarm ON delay	E11:ON DELAY1	1 sec.	E12:OFF DELAY2	3 sec.
Alarm OFF delay	E13:OFF DELAY1	2 sec.	E14:OFF DELAY2	4 sec.
Description of alarm actions	The alarm sounds if the condition where the input value is 80% or more of high-limit alarm continues for more than 1 second. After the alarm sounds, when the condition where input value is less than 70% of the high-limit alarm continues for more than 2 seconds, the status returns to normal.		The alarm sounds if the condition where the input value is 15% or less of low-limit alarm continues for more than 3 seconds. After the alarm sounds, when the condition where input value is more than 20% of the low-limit alarm continues for more than 4 seconds, the status returns to normal.	

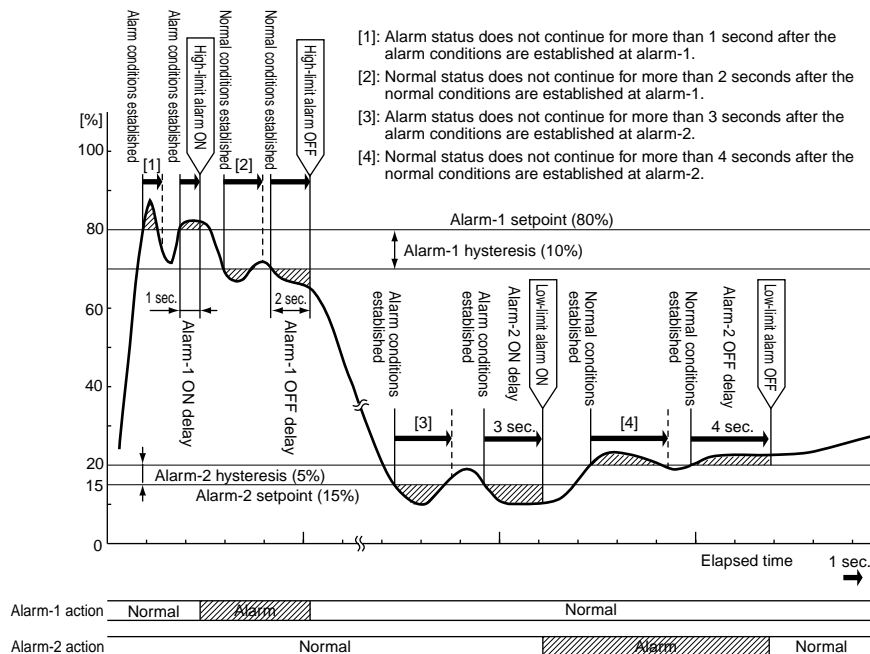

10.LIST OF PARAMETERS

No.	Item	Display	Remarks	No.	Item	Display	Remarks
01	Model	MODEL					
02	Tag no.	TAG NO					
03	Self-check result	SELF CHK					
Display items							
A	Display 1	DISPLAY1		B	Display 2	DISPLAY2	
A05	Output value 1	OUTPUT1		B05	Output value 1	OUTPUT1	
A06	Output value 2	OUTPUT2		B06	Output value 2	OUTPUT2	
A07	Alarm-1 status	ALM1 STATUS		B07	Alarm-1 status	ALM1 STATUS	
A08	Alarm-2 status	ALM2 STATUS		B08	Alarm-2 status	ALM2 STATUS	
A17	Status	STATUS	*1	B60	Self-check result	SELF CHK	
A18	Rev. no.	REV NO		*1 The Status is displayed for service personnel to see history records.			
A20	Menu rev.	MENU REV					
A60	Self-check result	SELF CHK					
Setting items							
D	Setting (I/O)	SET(I/O)		E	Setting (alarm output)	SET(ALM)	
D01	Tag no. 1	TAG NO.1		E01	Alarm-1 setting	SET POINT1	
D02	Tag no. 2	TAG NO.2		E02	Alarm-2 setting	SET POINT2	
D03	Comment 1	COMMENT1		E03	Alarm-1 setting	SET POINT1	
D04	Comment 2	COMMENT2		E04	Alarm-2 setting	SET POINT2	
D30	Baud out	BAUD OUT		E05	Direction of alarm-1 action	ALM1 ACTION	
D38	Direction of output-1 action	OUT1 DR		E06	Direction of alarm-2 action	ALM2 ACTION	
D39	Direction of output-2 action	OUT2 DR		E09	Alarm-1 hysteresis	HYSTERESIS1	
D60	Self-check result	SELF CHK		E10	Alarm-2 hysteresis	HYSTERESIS2	
There are items not displayed depending on what output-2 is specified.				E11	Alarm-1 ON delay setting	ON DELAY1	
				E12	Alarm-2 ON delay setting	ON DELAY2	
				E13	Alarm-1 OFF delay setting	OFF DELAY1	
				E14	Alarm-2 OFF delay setting	OFF DELAY2	
				E15	Direction of alarm-1 relay action	RL1 ACTION	
				E16	Direction of alarm-2 relay action	RL2 ACTION	
				E60	Self-check result	SELF CHK	
				F	Setting (communication)	SET(COM)	
				F01	Communication protocol	PROTOCOL	
				F02	Address	ADDRESS	
				F03	Baud rate	BAUD RATE	
				F04	Parity	PARITY	
				F05	Data length	DATA LEN	
				F06	Stop bit	STOP BIT	
F60	Self-check result	SELF CHK					
Adjusting items				Test items			
P	Adjustment	ADJUST1		Q	Test	TEST	
P10	Zero adjustment of input-1	ZERO ADJ1		Q02	Forced output 1	OUT1 TEST	
P11	Span adjustment of input-1	SPAN ADJ1		Q03	Forced output 2	OUT2 TEST	
P12	0% adjustment of output-1	OUT1 0%		Q04	Forced output (alarm 1)	ALM1 TEST	
P13	100% adjustment of output-1	OUT1 100%		Q05	Forced output (alarm 2)	ALM2 TEST	
P14	0% adjustment of output-2	OUT2 0%		Q60	Self-check result	SELF CHK	
P15	100% adjustment of output-2	OUT2 100%					
P60	Self-check result	SELF CHK					

11. MAINTENANCE

The product starts running immediately when the power is turned on; however, it needs 10 to 15 minutes of warm-up before it meets the specified performance.

For cleaning the instrument, use a soft and dry cloth.

11.1 Calibration Apparatus

- Two 6 dial variable resistors (Yokogawa M&C 2793 01 or the equivalent)
- A voltmeter (Yokogawa 7562 or the equivalent)
- A precision resistor of $250\ \Omega \pm 0.01\%$, 1W (for current output)

11.2 Calibration Procedure

Connect the instruments as shown in Fig. 11.1. First adjust Output-1 signal and then Output-2 signal.

Operate the variable resistor according to the specifications (full resistance, 0%, 100% resistance) of the potentiometer to be connected. Change the values of R1 and R2 on keeping the full resistance fixed, and then produce input signals equivalent to 0, 25, 50, 75, and 100% of the input span to the transmitter. Check that the transmitter's output signal shows voltages corresponding to 0, 25, 50, 75, and 100% of the input span within the rated accuracy range.

If the output signal is out of the rated accuracy range, adjust the output signal level using a PC (VJ77 PC-based parameters setting tools) or the Handy Terminal (JHT200). For information on adjustment, refer to the Instruction Manual for VJ77 PC-based Parameters Setting Tool (IM 77J01J77-01E) or the Instruction Manual for JHT200 Handy Terminal (IM JF81-02E).

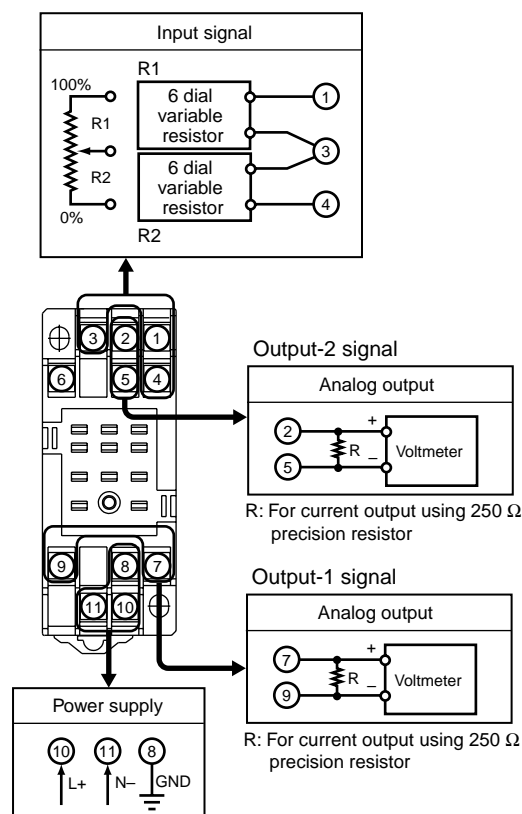

Fig. 11.1